

Novel Organic SMD Package for High-Power Millimeter Wave MMICs

M. van Heijningen¹, J. Priday²

¹TNO Physics and Electronics Laboratory (TNO-FEL), Oude Waalsdorperweg 63, 2597 AK, The Hague, The Netherlands, email: M.vanHeijningen@fel.tno.nl

²Labtech Limited, Broadaxe Business Park, Presteigne, LD8 2UH, United Kingdom, email: j.priday@labtech.ltd.uk

Abstract — In this paper a novel low-cost SMD package for high-power MMICs is presented. Due to the special design this package has a very low thermal resistance and low parasitic ground inductance. 3D EM simulations of a packaged through-line correspond well with measurements. Measurement results of a 1 Watt 40 GHz HPA before and after packaging are presented. The gain reduction at 40 GHz caused by the package is only 1 dB. Experimental results are given for different package options: with or without compensation circuit on the package and with or without bondwire compensation on the MMIC.

I. INTRODUCTION

In the past MMICs have generally been provided as bare die components and have been used by module manufacturers as chip-on-board components. The handling and mounting of bare die MMICs is a difficult and costly process and requires specialized equipment. Recently more and more MMICs are provided as packaged Surface Mount Device (SMD) components, mainly up to K-band frequencies [1]-[5]. These packaged MMICs can be handled like any other SMD components and allow cheaper and simpler module manufacturing. The main problems of this approach are that the SMD package can degrade the performance of the MMIC, or even cause instability, and pose a limit on the maximum allowed thermal dissipation. These problems are caused by the fact that the MMIC is not mounted directly on a ground plane but at some distance from the ground, corresponding to the thickness of the package substrate. Therefore, careful design, simulation and analysis of these packages are required.

In this paper a novel low-cost organic SMD package is presented that can be used up to 40 GHz and allows a power dissipation of at least 7 Watt. During the development, special attention was paid to the very high thermal conductivity and low added ground inductance. First, the package technology will be described with results from 3D EM simulations, followed by experimental results on a packaged through-line and several packaged 40 GHz high-power amplifier (HPA) MMICs.

II. PACKAGE TECHNOLOGY

The package is constructed from a single layer of 200 μm thick Rogers 4003, clad with copper on both sides. In this substrate a cavity is created that extends all the way to the bottom copper layer. Next, this cavity is plated with approximately 80 μm copper, so that the top of the MMIC will be level with the top of the substrate. The RF and DC signals are connected from the top of the substrate to solder pads at the bottom with vias. A standard ceramic lid or a full custom designed organic lid can be added. Fig. 1 shows a cross section of the package.

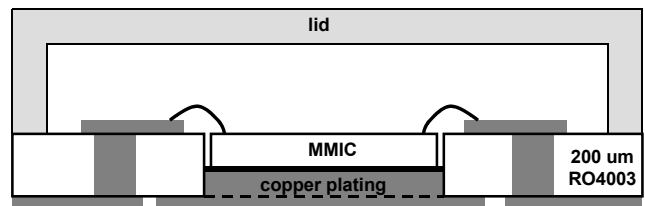

Fig. 1. Cross section of the organic package.

The advantages of this cavity construction are the very good heat transportation to the ground plane and the very low added ground inductance. Also very short (wedge-wedge) RF bondwires can be used since the top of the MMIC is level with the RF line in the package. Furthermore, barcaps can be included in the cavity for DC bias decoupling and the RF signal line can contain compensation circuits (stub and line filters) to compensate for the bondwire discontinuity. Fig.2 shows the top and bottom view of an empty package.

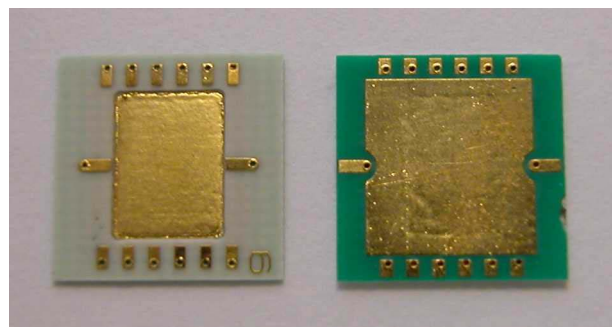

Fig. 2. Top and bottom view of the organic package.

III. DESIGN, EM AND THERMAL SIMULATIONS

The package technology described in the previous section has been modeled in a 3D EM simulator (HFSS) in order to evaluate the performance and design the optimum layout. Parameters that can be tuned are the line widths, via diameter and shape of the ground plane (within the given design rules). A cross section of the optimized 3D model is shown in Fig. 3. The simulated return and insertion loss for the board to package transition are shown in Fig. 4. As can be seen, the return loss is better than 15 dB and the loss is less than 0.3 dB up to 50 GHz.

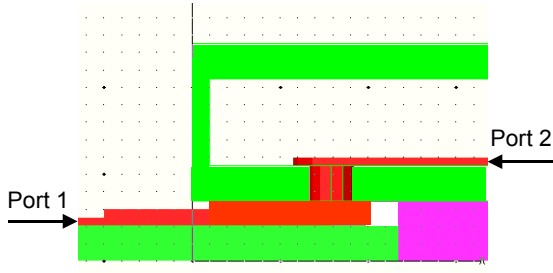

Fig. 3. Cross section of the 3D package via model.

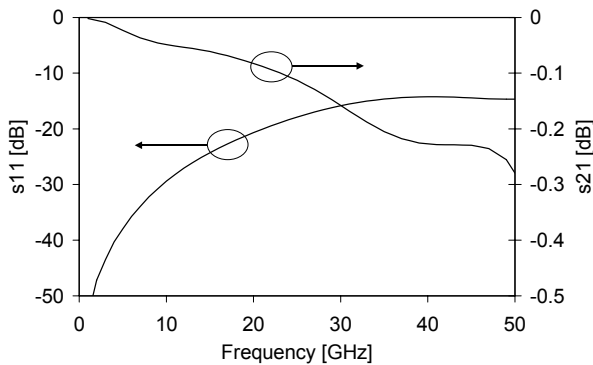

Fig. 4. Simulated return and insertion loss for 1 package via.

Thermal simulations have been performed on the package construction to analyze the maximum allowable heat dissipation. Since the MMIC is mounted on the copper plating in the cavity, which is itself soldered to the ground pad of a printed circuit board, the package causes almost no increase in thermal resistance. The major contributors to the total thermal resistance from junction to ground plane or ambient are the epoxy for mounting the MMIC in the cavity, although this can be a high thermal conductive epoxy, and, if present, the ground vias in the printed circuit board. From a thermal point of view there is almost no difference between mounting a bare die directly on a metal heatsink or using this package. The maximum allowable power dissipation in this package is not limited by the package itself, but by the construction of the motherboard beneath the package.

IV. EXPERIMENTAL RESULTS

To verify the simulations and to measure the performance of the organic packages, HPA and test samples have been mounted on a 200 μm thick RO4003 testboard with metal backplate. The mounting of these packages is performed with a standard soldering process used for SMD components. Fig. 5 shows a 50 Ω through-line package mounted on a testboard.

Small signal S-parameter measurements from 45 MHz to 50 GHz have been performed using an HP8510 network analyzer. The RF signal is applied using ground-signal-ground wafer probes. These probes, including the probe pads, have been calibrated using a Thru-Line-Reflect (TRL) calibration standard on a similar piece of organic testboard. These reference planes are indicated in Fig. 5.

The measured and simulated reflection of the packaged through-line is shown in Fig. 6. The simulation results have been obtained by back-to-back combining of the simulated s-parameters from the model in Fig. 3. The measured and simulated return loss corresponds very well, considering all the multiple reflections that occur in this test structure.

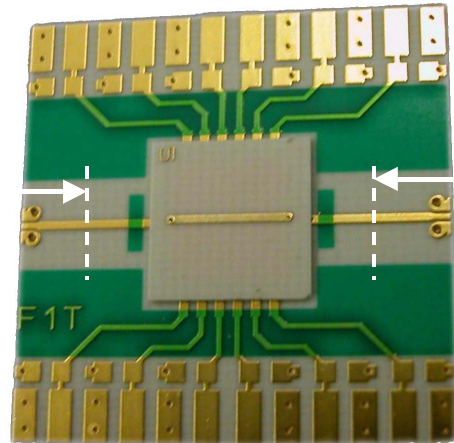

Fig. 5. Test structure for package through-line measurement.

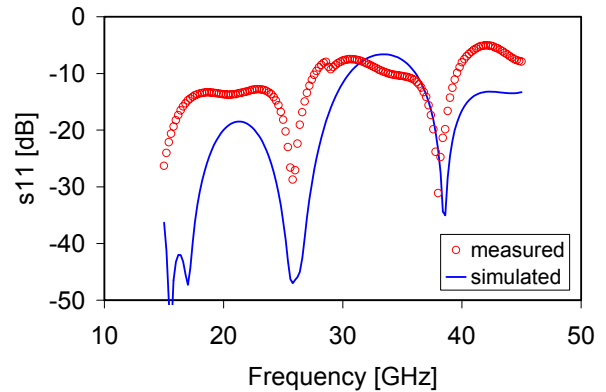

Fig. 6. Measured and simulated through-line return loss.

Several different combinations of packages and HPAs have been analyzed: with or without bondwire compensation on the MMIC and with or without compensation stubs in the package. The HPA is designed for the frequency range of 36-40 GHz with 30 dBm output power and 15 dB of gain in the experimental PPH15X process of UMS. Lange couplers have been used at the input and output to ensure a good return loss. Barcaps for the bias decoupling have been included in the cavity of the HPA package. Fig. 7 shows a photograph of a packaged HPA (without lid). Fig.8 shows a close-up of the different compensation options: a compensation network included in the package and a bondwire compensation circuit on-chip.

Before packaging, measurements have been performed on diced MMICs at reduced gate bias. These results are compared to measurements of the same die but now in the package.

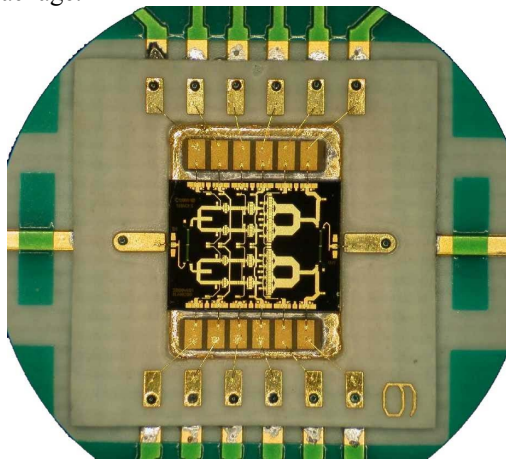

Fig. 7. Packaged HPA MMIC including barcaps.

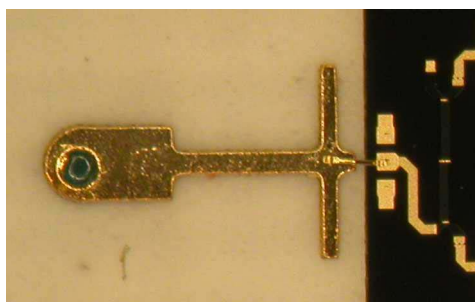
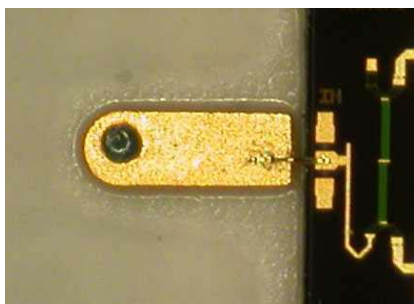

Fig. 8. Close-up of different bondwire compensation options: on the package and/or on-chip.

Fig. 9 shows the on-wafer measured return loss and the return loss of the package HPA. In this version there is no bondwire compensation on-chip and the on-wafer return loss is very good because of the Lange Coupler. The return loss of this HPA in a standard package without compensation is still better than 10 dB in the frequency band of interest. As can be seen, no instability is present for the packaged HPA.

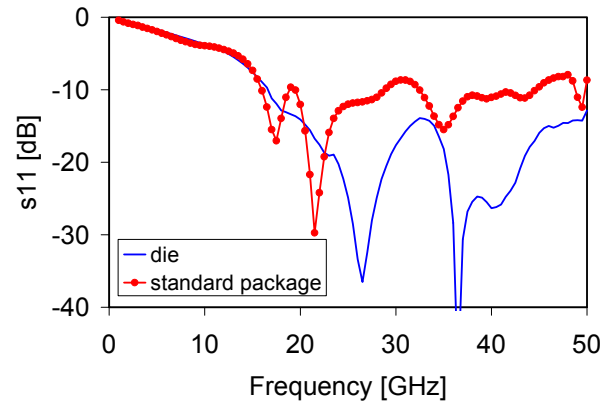

Fig. 9. Measured HPA return loss before and after packaging.

To study the effect of the compensation options, several different combinations of HPAs and packages have been measured. These results are shown in Fig. 10.

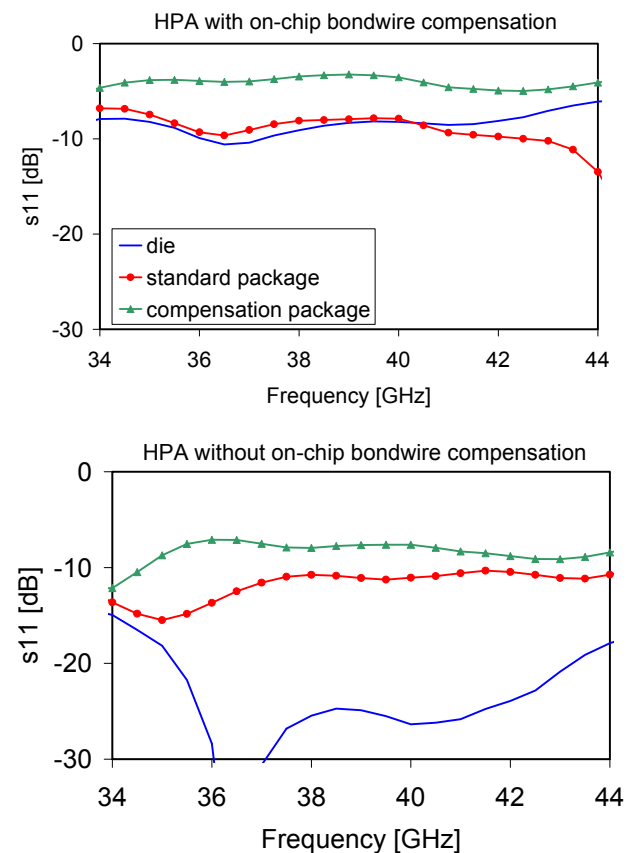

Fig. 10. Measured return loss before and after packaging for different compensation options.

The first graph shows the measured return loss for an HPA with bondwire compensation on-wafer and in two different packages. It is clear that the on-chip bondwire compensation increases the return loss when measured on-wafer (without bondwire). When this HPA is mounted in a package with extra compensation, the return loss becomes worse due to over-compensation. When this HPA is mounted in a standard package, without compensation, the return loss is almost not affected by the packaging.

The second graph in Fig. 10 shows the results for an HPA without on-chip bondwire compensation. Even in this case, the package with extra compensation results in the worst return loss, and the standard package without compensation is the best solution. Most likely the compensation circuit on the package is designed too critical and causes too much compensation.

Finally the extra insertion loss caused by the packaging has been measured, for both open packages and packages with a lid. Fig. 11 shows the packaged HPA with a lid constructed from FR4. Other lids made from Rogers material or ceramics are also possible.

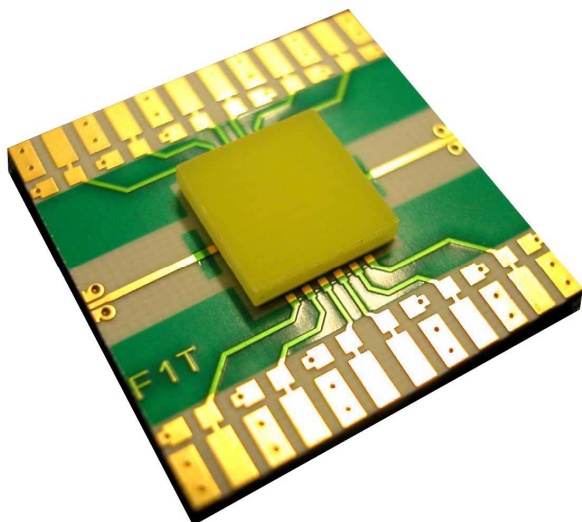

Fig. 11. Packaged HPA MMIC including lid mounted on the organic testboard.

Fig. 12 shows the measured small signal gain of the bare-die HPA and the packaged version with and without lid. The loss caused by the two package transitions is around 1.1 dB for the open version and 1.5 dB for the closed package at 40 GHz.

V. CONCLUSION

A novel low-cost SMD package has been presented that can be used for high-power millimeter wave MMICs. The package contains a special cavity construction that

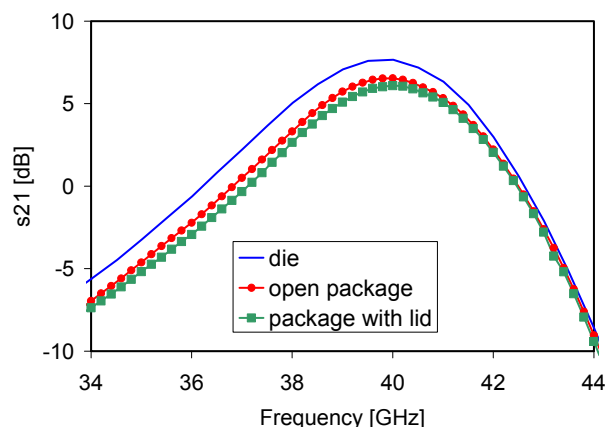

Fig. 12. Measured HPA small signal gain before and after packaging.

ensures a very good thermal conductivity and low ground inductance. The package design using 3D EM simulations has resulted in a very low insertion loss of 1.5 dB at 40 GHz, and the return loss of the packaged HPA is better than 10 dB. Results have been shown on several HPA MMICs before and after packaging, showing the feasibility of low-cost SMD packaging at millimeter-wave frequencies.

ACKNOWLEDGEMENT

This work has been funded by the EC within the 5th framework SMACKS project (IST-2000-30060). The package technology has been developed by Labtech. The packages and testboards have also been produced by Labtech. The authors would like to thank Gildas Gauthier of Thales Airborne Systems and Pierre Quentin of UMS for their useful contributions to this work.

REFERENCES

- [1] K. Beilenhoff, P. Quentin, S. Tranchant, O. Vaudesca, M. Parisot and H. Daembkes, "Full 26 GHz Chipset for Telecom Applications in SMD-Type Packages", *Proc. European Gallium Arsenide and other Semiconductors Application Symp. (GAAS2002)*, pp. 331-334, Sep. 2002.
- [2] H.C. Huang, A. Ezzeddine, A. Darwish, B. Hsu, J. Williams, S. Peak, "Ku-Band MMICs in Low-Cost, SMT Compatible Packages", *IEEE MTT-S Int. Microwave Symp. Dig.*, vol. 1, pp. 27-30, 2002.
- [3] S. Morioka, Y. Sawa, "Surface mount package for high frequency band", *Proc. Asia Pacific Microwave Conference*, pp. 958-961, Dec. 1999.
- [4] M.P.R. Panicker, "Microwave and millimeter wave ball grid array (BGA) packages", *Proc. IEEE 7th topical Meeting on Electrical Performance of Electronic Packaging*, pp. 233-236, Oct. 1998.
- [5] A. Bessemoulin, M. Parisot and M. Camiade, "1-Watt Ku-band Power Amplifier MMICs using Low-cost Quad-Flat Plastic Package", *IEEE MTT-S Int. Microwave Symp. Dig.*, pp. 473-476, 2004.