

2 - 18GHz Switch Multiplexer

The Switch Multiplexer is a single RF input to single RF output, fast, multi-configurable filter bank covering 2 - 18GHz.

Consisting of 16 channels (2 - 18GHz), these are equally spaced 1GHz channels. Each channel is independently controlled, allowing 65536 possible combinations of overall filter response from input to output. In addition 8 tap out ports, split into 2GHz wide bands, are provided for monitoring purposes should this be required. In normal operation these are terminated in 50 ohm loads.

This provides the user with a fast, flexible, filter network capable of providing different band-pass or band-stop responses on a pulse-by-pulse basis in dense signal environments.

Filter control is achieved via Serial data lines on the VME backplane.

With internal amplification providing zero loss and low noise figure, together with flat insertion loss and exceptionally flat group delay, the filter is an ideal system enhancement.

Designed to withstand harsh military environments, the SA219 is a complete front-end filter solution allowing system designers to achieve functionality previously unattainable.

FEATURES

- Full 2 – 18GHz
- 16 Channels
- Low Noise Figure

APPLICATIONS

- Broadband EW Signal limiting
- Adaptive filtering
- RWR system protection
- Test lab filtering

See restrictions on published datasheets at www.teledynedefence.co.uk/

SPECIFICATIONS

Parameter	Specification
Frequency Range	2 to 18GHz
No of Channels	16
Channel Crossovers	2-3-4-5-6-7-8-9-10-11-12-13-14-15-16-17-18GHz
Noise Figure	8dB max in passband (single channel or output mux dual channel) 11dB max (8dB nom) in passband (any combination)
Input 1dB Compression	>0dBm
Control & Status	Serial data lines on VME P2 connector
Insertion Loss Window	-2 to +2dB at ambient across selected channels
IL Window Variation Across Temp	<0.025dB/degC
Group Delay Variation	6ns (in passband)
Rejection	Band edge +/- 500MHz 30dB Band edge +/- 1GHz 50dB
Input/Output Impedance	50 Ohm, standard SMA (f)
VSWR	Input 2.5:1
Operating Temperature	-40 to +85 deg C
DC Power	+5V 750mA max -12V 100mA max 5W max
Mechanical	6U x 4HP VME Form factor, single slot

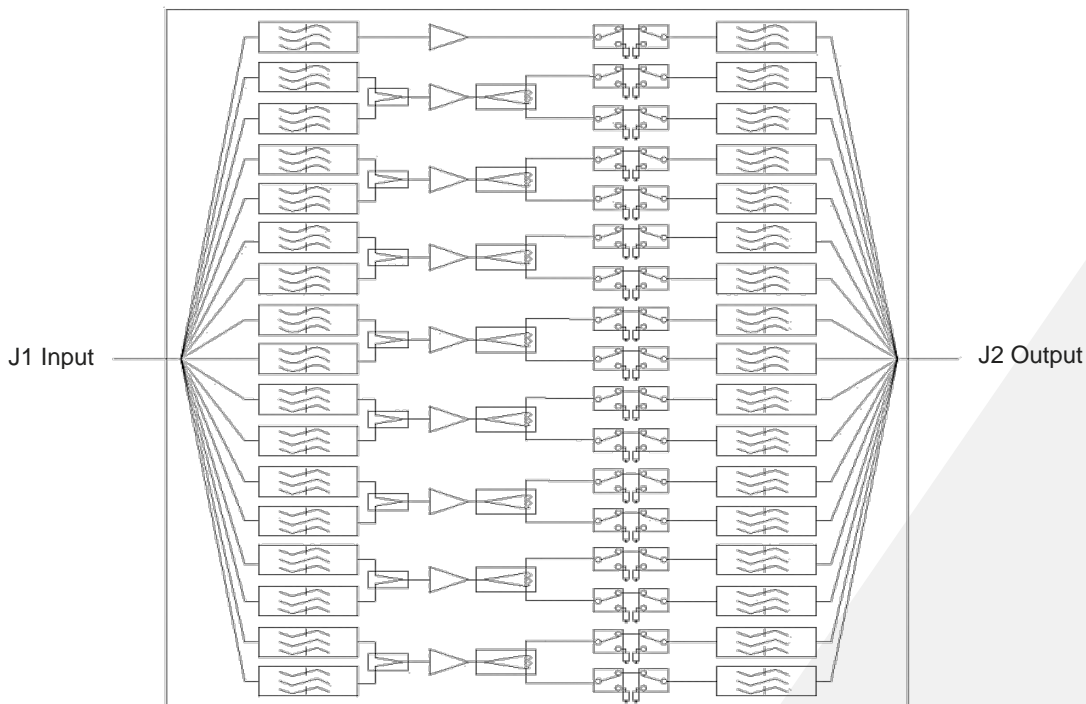

See restrictions on published datasheets at www.teledynedefence.co.uk/

PERFORMANCE DATA Insertion Loss and Rejection

The following plots show the filter in differing states, showing the true switch multiplexer nature of the SA219.

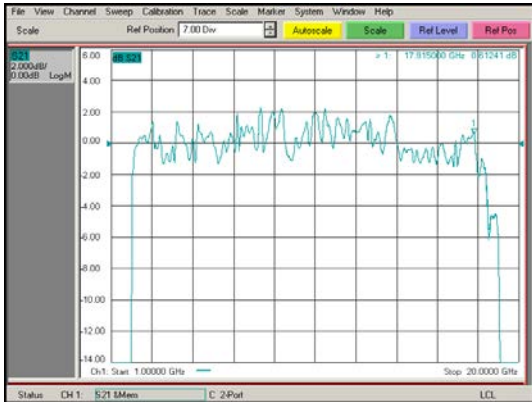

Fig 1. All pass Response

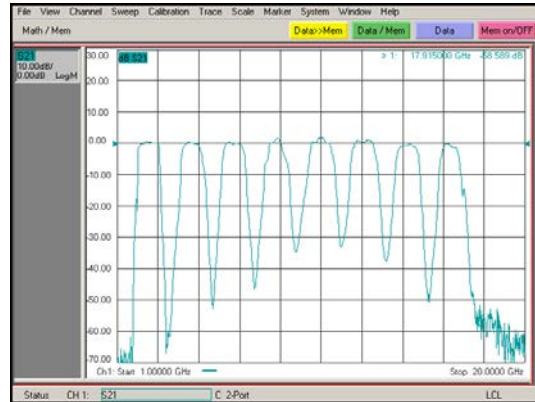

Fig 2. S21, Odd channels 'ON'

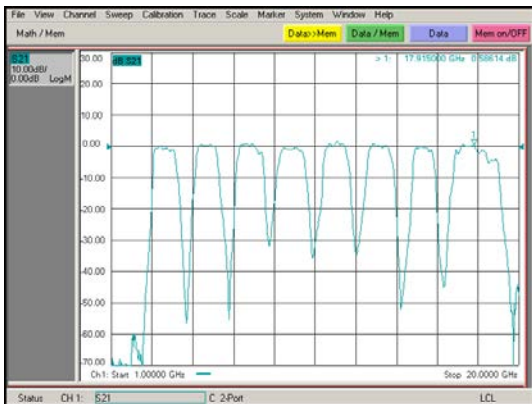

Fig 3. S21, Even channels 'ON'

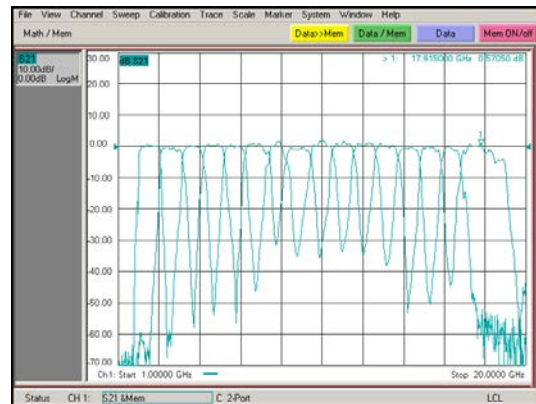

Fig 4. S21, overlay of individual channels

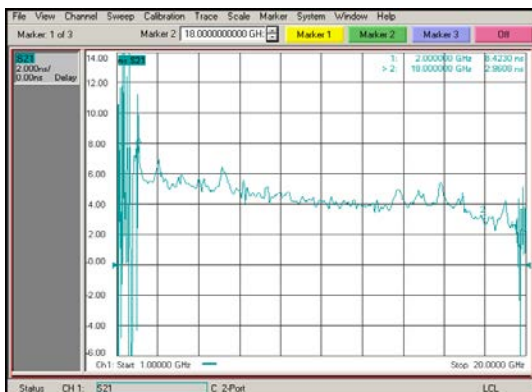

Fig 5. Full band group delay response

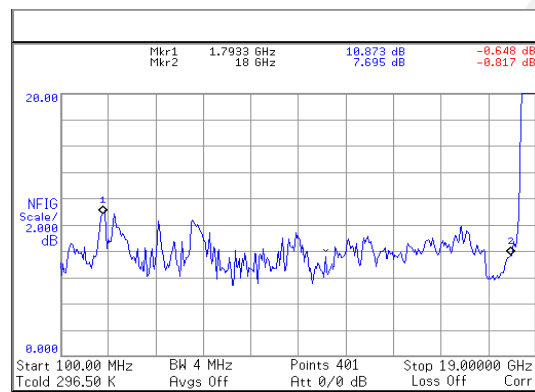

Fig 6. Noise Figure Plot: nominal

See restrictions on published datasheets at www.teledynedefence.co.uk/